

## Detail 8.2.4

### Exterior and Interior Insulated 2x6 Wood Stud (16" o.c.) Wall Assembly with Wood Strapping Supporting Fiber Cement Board and R-19 Batt Insulation in Stud Cavity – Independently Supported Balcony Intersection

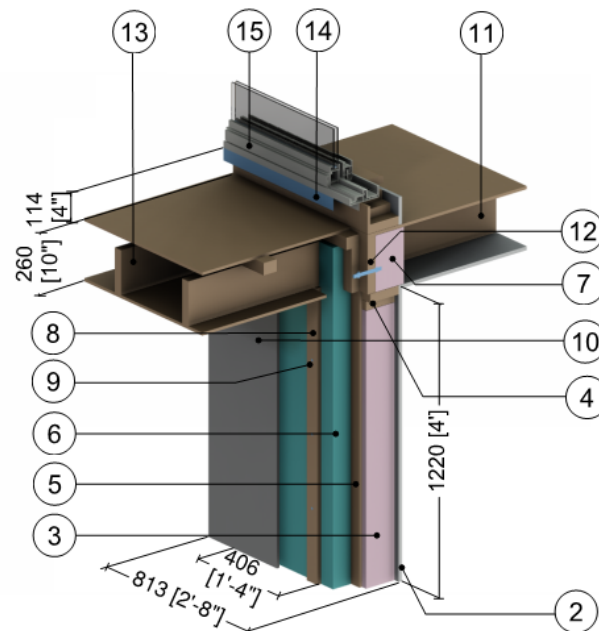

ID	Component	Thickness Inches (mm)	Conductivity Btu·in / ft <sup>2</sup> ·hr·°F (W/m K)	Nominal Resistance hr·ft <sup>2</sup> ·°F/Btu (m <sup>2</sup> K/W)	Density lb/ft <sup>3</sup> (kg/m <sup>3</sup> )	Specific Heat Btu/lb·°F (J/kg K)
1	Interior Film <sup>1</sup>	-	-	R-0.6 to R-0.9 (0.11 RSI to 0.16 RSI)	-	-
2	Gypsum Board	1/2" (13)	1.1 (0.16)	R-0.5 (0.08 RSI)	50 (800)	0.26 (1090)
3	Fiberglass Batt Insulation	5 1/2" (140)	0.29 (0.042)	R-19 (3.3 RSI)	0.9 (14)	0.17 (710)
4	2x6 Wood Stud (16" o.c.)	5 1/2" (140)	0.69 (0.10)		31 (500)	0.45 (1880)
5	Exterior Plywood Sheathing	1/2" (13)	0.69 (0.10)	R-0.7 (0.12 RSI)	31 (500)	0.45 (1880)
6	Exterior Insulation	Varies	-	R-10 to R-15 (1.76 RSI to 2.64 RSI)	1.8 (28)	0.29 (1220)
7	Fiberglass Batt Insulation at Joist	5 1/2" (140)	0.29 (0.042)	R-19 (3.3 RSI)	0.9 (14)	0.17 (710)
8	1x3 Wood Strapping	3/4" (19)	0.69 (0.10)	-	31 (500)	0.45 (1880)
9	Steel Fasteners (16" o.c.)	0.35" (9) Ø	347 (50)	-	489 (7830)	0.12 (500)
10	Fiber Cement Board Cladding with 3/4" (19mm) vented airspace incorporated into exterior heat transfer coefficient					
11	2x10 Wood Joist (16" o.c.)	9 1/4" (235)	0.69 (0.10)	-	32 (510)	0.45 (1880)
12	2x10 Rim Joist	1 1/2" (38)	0.69 (0.10)	-	31 (500)	0.45 (1880)
13	2x8 Wood Balcony Joists (16" o.c.)	5 1/2" (140)	0.69 (0.10)	-	31 (500)	0.45 (1880)
14	Steel Flashing	18 Gauge	430 (62)	-	489 (7830)	0.12 (500)
15	Aluminum Sliding Door: double glazed & thermally broken <sup>2</sup> , double glazed IGU U <sub>IGU</sub> = 0.32 BTU/hr·ft <sup>2</sup> ·°F (1.82 W/m <sup>2</sup> K)					
16	Exterior Film <sup>1</sup>	-	-	R-0.2 to R-0.7 (0.03 RSI to 0.12 RSI)	-	-

<sup>1</sup> Value selected from table 1, p. 26.1 of 2009 ASHRAE Handbook – Fundamentals depending on surface orientation

<sup>2</sup> The thermal conductivity of air spaces within framing was found using ISO 100077