

# Detail 5.1.100

## Exterior and Interior Insulated 6" x 1 5/8" Steel Stud (16" o.c.) Wall Assembly with EJOT Crossfix Console and Horizontal Rail System Supporting Metal Cladding and R-20 Batt Insulation in Stud Cavity - Clear Wall

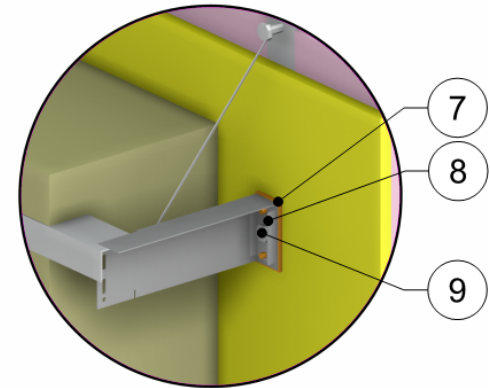
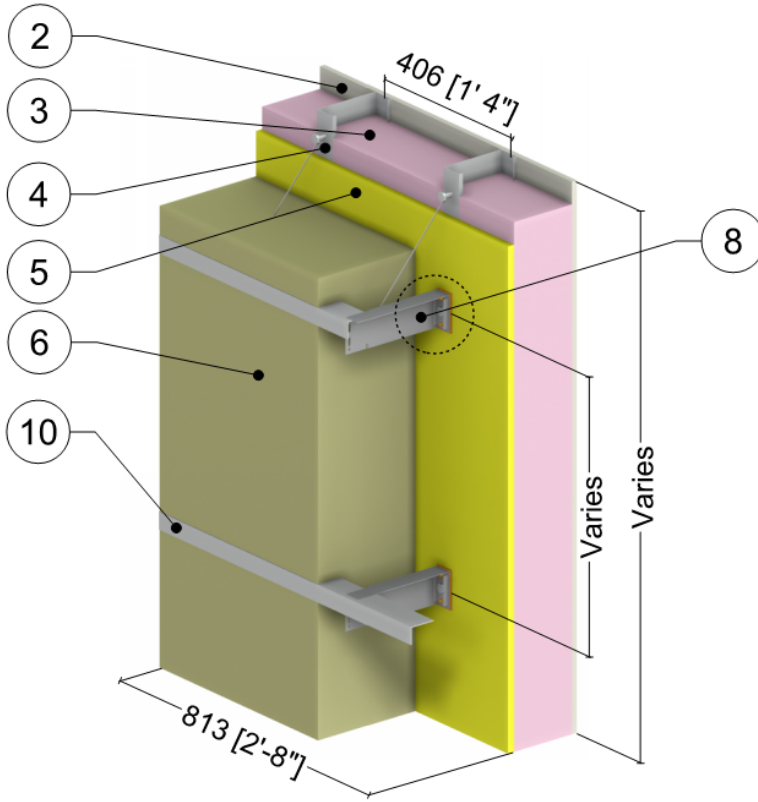

Console Detail

Exterior Insulation Thickness for Console Sizes

Crossfix Console Size	Exterior Insulation Thickness in (mm)
40	2 (51)
80	3.5 (89)
120	5 (127)
200	8.5 (216)
240	10 (254)
320	13 (330)
400	16 (406)

ID	Component	Thickness Inches (mm)	Conductivity Btu·in / ft <sup>2</sup> ·hr·°F (W/m K)	Nominal Resistance hr·ft <sup>2</sup> ·°F/Btu (m <sup>2</sup> K/W)	Density lb/ft <sup>3</sup> (kg/m <sup>3</sup> )	Specific Heat Btu/lb·°F (J/kg K)
1	Interior Film <sup>1</sup>	-	-	R-0.7 (0.12 RSI)	-	-
2	Gypsum Board	1/2" (13)	1.1 (0.16)	R-0.5 (0.09 RSI)	50 (800)	0.26 (1090)
3	Fiberglass Batt Insulation	6" (152)	0.30 (0.043)	R-20 (3.5 RSI)	0.55 (8.8)	0.17 (710)
4	6" x 1 5/8" Steel Studs	18 Gauge	430 (62)	-	489 (7830)	0.12 (500)
5	Exterior Sheathing	5/8" (16)	1.1 (0.16)	R-0.6 (0.10 RSI)	50 (800)	0.26 (1090)
6	Exterior Mineral Wool Insulation	Varies	0.24 (0.034)	R-8.4 to R-67.2 (1.48 to 11.84 RSI)	4 (64)	0.20 (850)
7	Thermostop	0.2" (5)	2.2 (0.32)	-	69 (1100)	0.36 (1500)
8	EJOT Console and Components	0.06" (1.5)	112 (16)	-	499 (8000)	0.12 (500)
9	Fastener	0.22" (5.5) Ø	112 (16)	-	499 (8000)	0.12 (500)
10	Rail	0.08" (2)	1110 (160)	-	-	-
11	Cladding with 1/2" vented airspace incorporated into exterior heat transfer coefficient					
12	Exterior Film <sup>1</sup>	-	-	R-0.7 (0.12 RSI)	-	-

<sup>1</sup> Value selected from table 1, p. 26.1 of 2009 ASHRAE Handbook – Fundamentals depending on surface orientation